

Kleinlüfter
Fan

KL 100

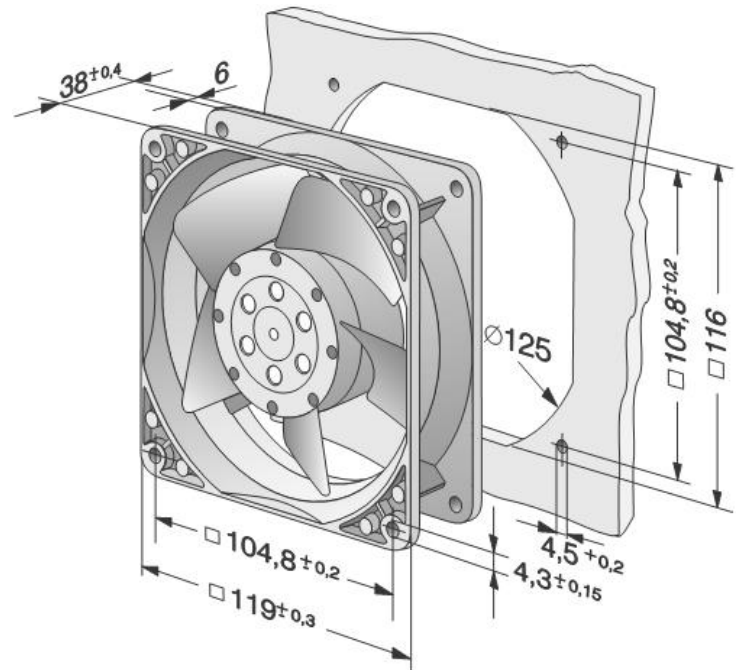

Type:	KL 100 X 24V DC	KL 100 X 115V 50/60Hz KL 100 S 115V 50/60Hz	KL 100 X 230V 50/60Hz KL 100 S 230V 50/60Hz
Volumenstrom Volume flow	184m ³ /h	160/180m ³ /h	160/180m ³ /h
Leistungsaufnahme Power input	4,1W	20W	19/18W
Gehäuse Housing	Kunststoff Plastic	Aluminium Druckguß Die-cast aluminium	Aluminium Druckguß Die-cast aluminium
Lüfterflügel Impeller	Kunststoff Plastic	Stahlblech Sheet steel	Stahlblech Sheet steel
Lager Bearing	Kugellager Ball bearing	Gleitlager / Kugellager Slide - / Ball - bearing	Gleitlager / Kugellager Slide - / Ball - bearing
Temperaturbereich Temperature range	-20...+70°C	-10...+60°C / -40...+85°C	-10...+50°C / -40...+75°C
Nenn Drehzahl Speed	3300 min ⁻¹	2650/3100 min ⁻¹	2650/3100 min ⁻¹
Lebensdauer bei 40°C Service life	65.000 h	40.000 h	37.500 h
Geräuschpegel Noise level	42 dB(A)	40/45 dB(A)	40/45 dB(A)
Anschlußart Connection	Anschlußklemme Terminal	X: Anschlußklemme Terminal S: Steckfahnen 2,8 x 0,5 Plug connection	X: Anschlußklemme Terminal S: Steckfahnen 2,8 x 0,5 Plug connection
Zulassungen Approvals	CE, UL, CSA	CE, UL, CSA	CE, UL, CSA